

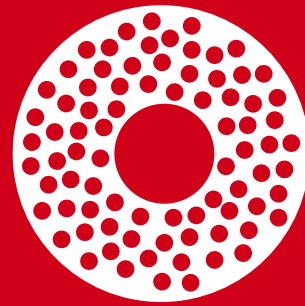

ARNOLD
GRUPPE 



FIBER
OPTICS
SPECIALITY FIBER



Company profile



Arnold Group is an innovative company specializing in the development and implementation of customized solutions in the fields of quartz glass processing (mostly for fiber optics & semiconductor production), glass processing, Silicon processing, as well as automation solution for the previously mentioned.

Since 1950, we have been offering our customers not only high-quality products but also comprehensive services tailored to their individual needs – from individual torches and tools to fully automated, robot feed machines.

Our portfolio for **specialty fiber customers** includes preform preparation machines, MCVD and FCVD systems, horizontal and vertical overcladding systems, and specialty fiber draw towers equipped with our own induction furnaces. We are also working on future developments such as customized OVD and rare earth chelate systems.

For our **telecommunication fiber customers** we offer cutting, grinding and welding machines for the core rod production as well as for the preform manufacturing process. Besides the well-known burner application, we offer future-oriented and energy-saving induction furnace as well as plasma burner solutions. In recent years, vertical and horizontal core rod drawing systems have been developed together with our customers.



Company profile:

- Founded 1950
- Head office in Weilburg / Germany
- Approx. 170 employees

The Arnold Gruppe consists of the following companies:

- Herbert Arnold GmbH & Co. KG
- Helmich Automationstechnik
- Heathway Ltd.
- B&C
- Arnold-Motion



Customized MCVD system

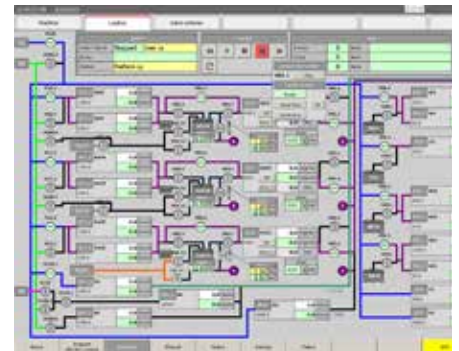
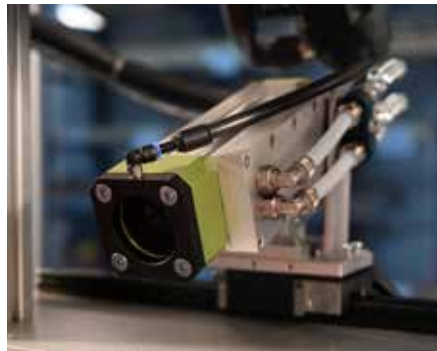



SPECIALTY FIBER

Customized FCVD/ MCVD system



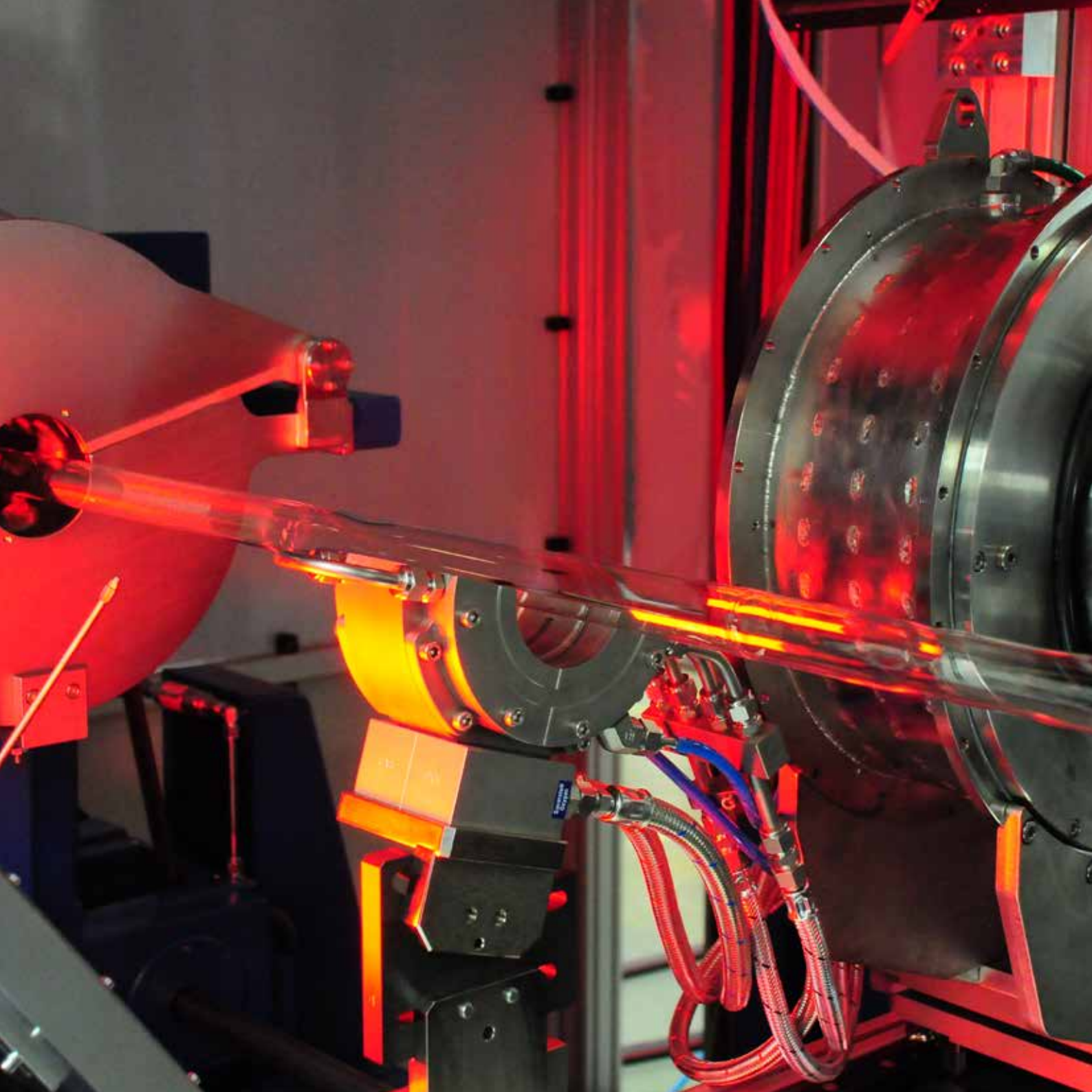



SPECIALTY FIBER

Draw Tower

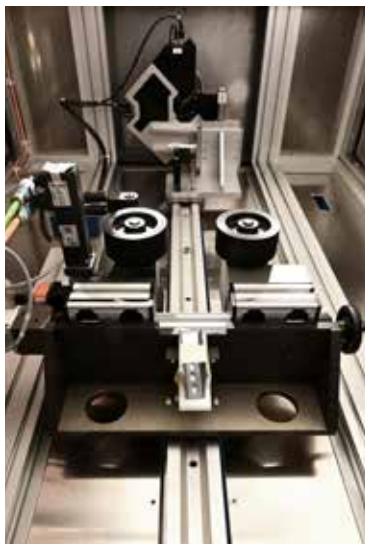

SPECIALTY FIBER



Draw Tower





OVD systems

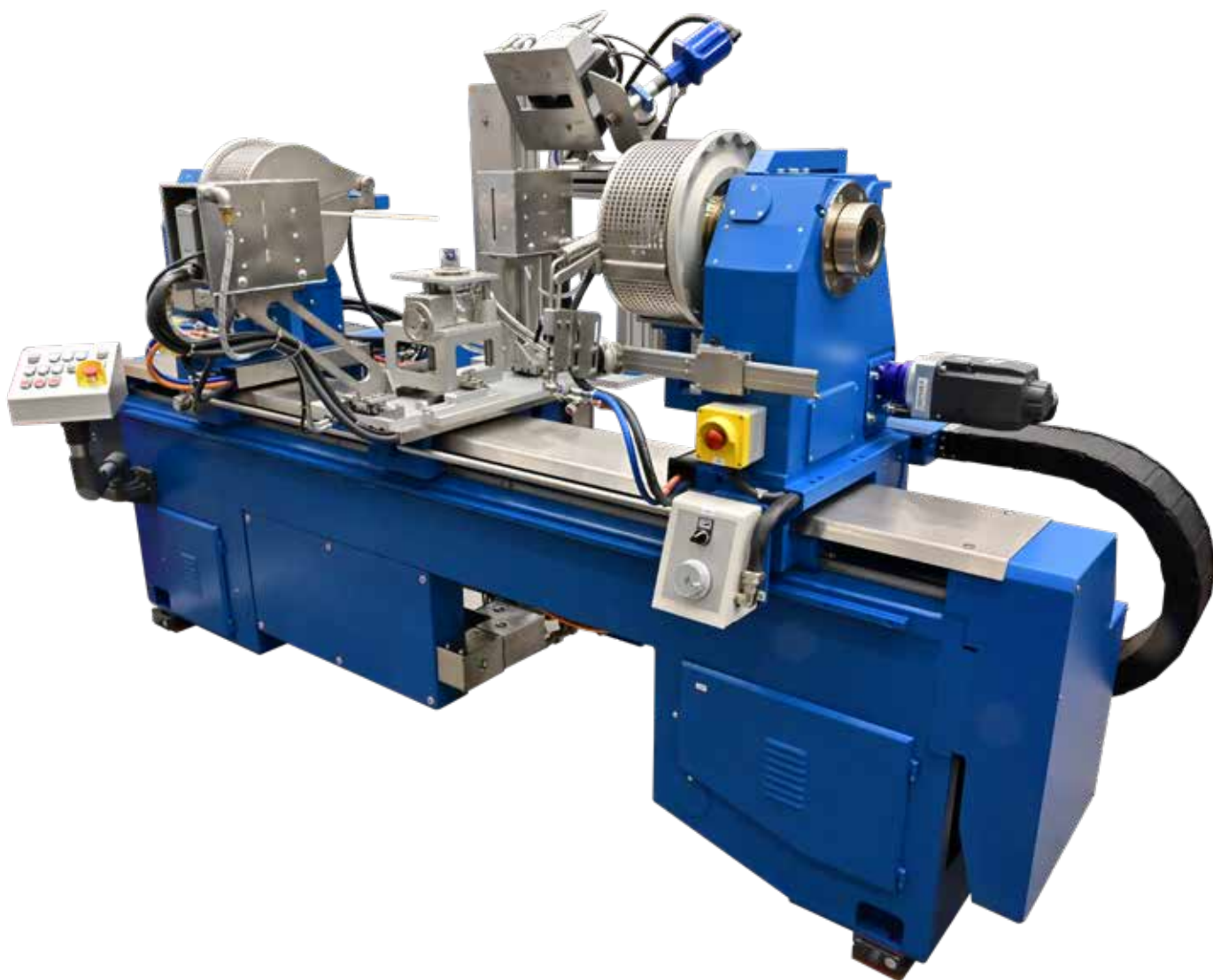

SPECIALTY FIBER



OVD systems





Induction furnaces for horizontal and vertical applications

We manufacture customised horizontal and vertical induction furnaces, including shutter solutions tailored to the application, as well as measurement technology for temperature, diameter and wall thickness.

Everything from a single source, including cooling water supply, cooling water distribution and inert gas distribution to the various zones via MFCs.

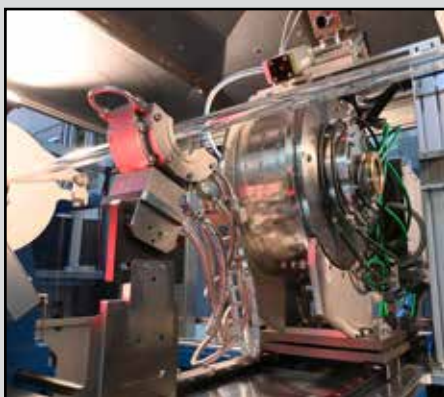

Furnaces for specialty draw towers

Vertical IF40



- 40 kW
- 8 ... 50kHz
- \varnothing max. 90 mm

FCVD / Overcladding / Sleeving

Horizontal IF60



- 60 kW
- 8 ... 30kHz
- \varnothing 40 / \varnothing 60 mm

Furnaces for stretching and collapsing

Vertical IF100



- 100 kW
- 8 ... 30kHz
- \varnothing 70 - \varnothing 110 mm

Resistance furnace for specialty drawing towers

(drawing of fibers or capillaries)

Vertical RF60



- 60 kW
- \varnothing max. 50 mm

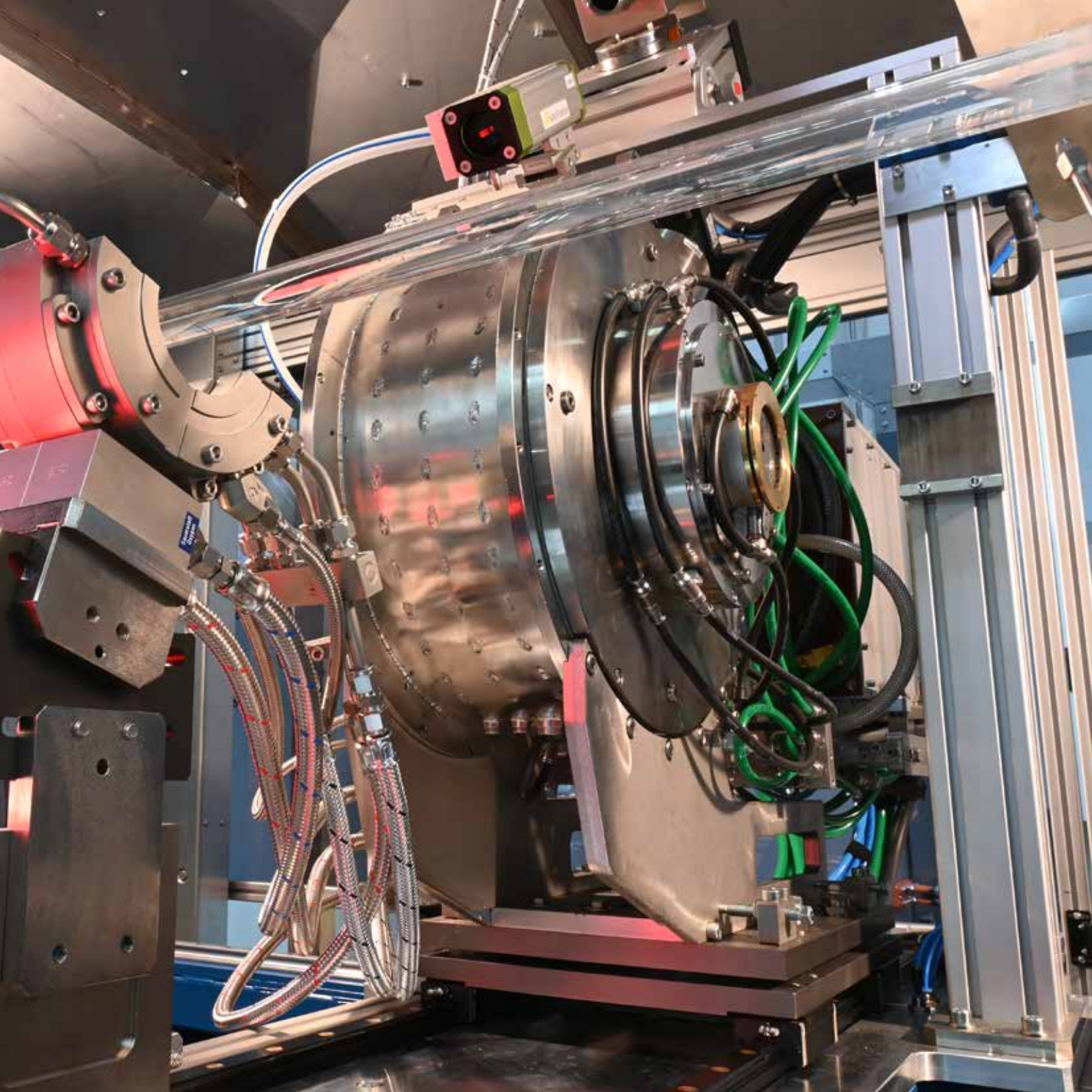



SPECIALTY FIBER

Overcladding vertical



Overcladding horizontal



Burners



141/18/6.3



141/41 WS-WK

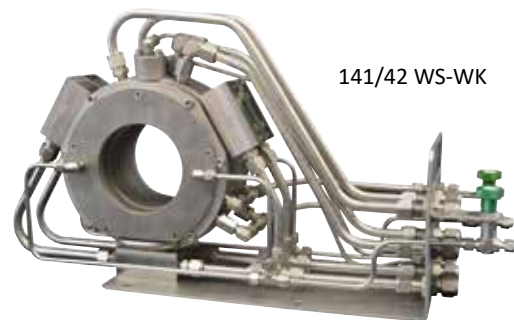

141/42 WS-WK

Hand burners



SSQ 141/5.008



SSQ 141/5 WS



141/18/60



Cutting machines



72/350
Cutting Saw



72 Niro
Universal
Cutting Saw

Chelate system (current development)

UNDER CONSTRUCTION



Heathway Upgrades



Since 2005, Heathway has been part of the Arnold Group, enriching our portfolio, which we continuously develop and refine.

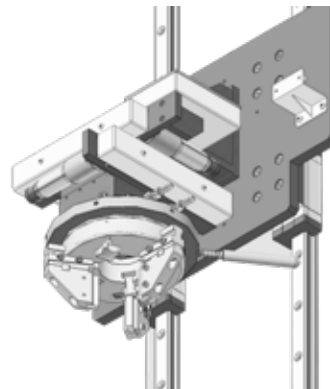
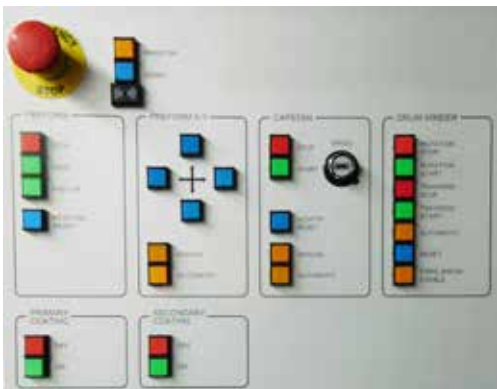



Herbert Arnold GmbH & Co.KG
Weilstrasse 6
D-35781 Weilburg, Germany

Telephone: +49 (0) 64 71 / 93 94 0
Telefax: +49 (0) 64 71 / 20 65
Mail: info@arnold-gruppe.de

www.arnold-gruppe.de



Visit Arnold on Facebook:
<http://www.facebook.com/ArnoldGruppe>

